

## PRODUCT DETAILS:-

### GICOB™ GA Model: Gate Valves Design

Design Options:

- Full Port
- Outside Screw and Yoke (OS&Y)
- Bolted Bonnet
- Flexible Wedge, Fully Guided
- Solid or Split Wedge
- Renewable Seat Rings
- Rising or Non-Rising Stem Handwheel
- Flanged, Butt-weld End

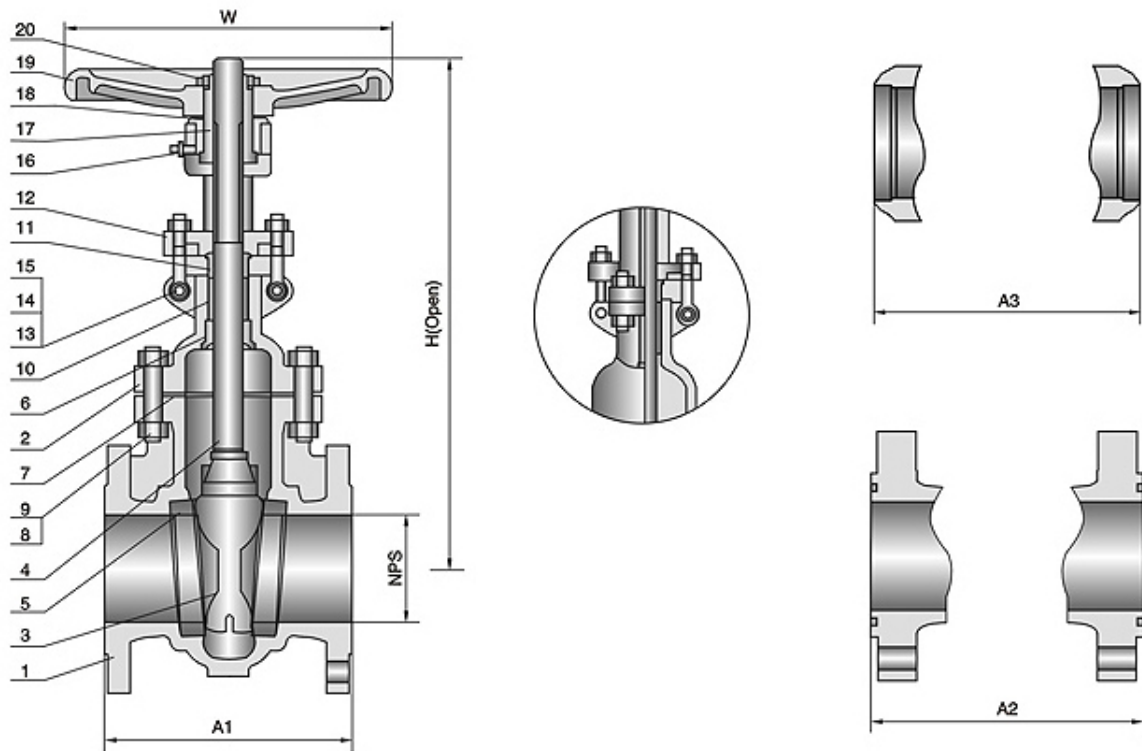

### GICOB™ GA Model: Gate Valve Part List

Item	Description	Valve Material						
		Carbon Steel	Alloy Steel		Stainless Steel			
1	Body	A216 WCB	A217 WC6	A217 WC9	A351 CF8	A351 CF8M	A351 CF3	A351 CF3M
2	Bonnet	A216 WCB	A217 WC6	A217 WC9	A351 CF8	A351 CF8M	A351 CF3	A351 CF3M
3	Wedge	WCB+13Cr	A217 WC6+HF	A217 WC9+HF	A351 CF8	A351 CF8M	A351 CF3	A351 CF3M
4	Stem	A182 F6A	A182 F11	A182 F22	A182 F304	A182 F316	A351 CF3	A351 CF3M
5	Seat Ring	A105+13Cr	A182 F11+HF	A182 F22+HF	N/A			
6	Back Seat	A276 410	A276 410		N/A			
7	Gasket	304+Graphite	304+Graphite		304+Graphite	316+Graphite	304L+Graphite	316L+Graphite
8	Bonnet Bolt	A193 B7	A193 B7		A193 B8	A193 B8M	A193 B8	A193 B8M
9	Bonnet Nut	A194 2H	A194 2H		A194 8	A194 8M	A194 8	A194 8M
10	Packing	Graphite		Graphite				
11	Gland	A276 410	A276 410		A276 304	A276 316	A276 304L	A276 316L
12	Gland Flange	A216 WCB	A216 WCB		A351 CF8			
13	Eyebolt	Carbon Steel	A193 B7		A193 B8			
14	Eyebolt Nut	Carbon Steel	A194 2H		A194 8			
15	Eyebolt Pin	A276 410		A276 304				
16	Nipple	Manufacturer's standard						
17	Stem Nut	Bronze						
18	Jam Nut	Carbon Steel	Carbon Steel		Stainless Steel			
19	Hand Wheel	Malleable Iron						
20	Wheel Nut	Carbon Steel	Carbon Steel		Carbon Steel+Zn			

Gate Valve Dimensions & Weights (150#, 300#, 600#)

NPS (in)	Class 150						Class 300						Class 600					
	A <sub>1</sub>	A <sub>3</sub>	H	W	Wt. (kg)		A <sub>1</sub> & A <sub>3</sub>	A <sub>2</sub>	H	W	Wt. (kg)		A <sub>1</sub> & A <sub>3</sub>	A <sub>2</sub>	H	W	Wt. (kg)	
					RF	BW					RF	BW					RF	BW
2	178	216	390	200	22	20	216	232	412	200	29	24	292	295	471	224	43	28
2.5	190	241	425	200	25	21	241	257	450	200	40	35	330	333	495	224	60	45
3	203	283	461	200	30	28	283	298	483	224	48	37	356	359	561	250	70	60
4	229	305	580	250	45	42	305	321	601	250	74	64	432	435	677	300	134	104
6	267	403	776	300	85	73	403	419	813	355	142	122	556	562	944	450	285	205
8	292	419	976	355	134	111	419	435	1020	400	220	172	660	664	1110	500	448	313
10	330	457	1178	450	202	181	457	473	1239	450	327	232	787	791	1323	560	680	535
12	356	502	1387	450	290	265	502	518	1443	500	496	391	838	841	1675	560	1068	973
14	381	572	1523	500	370	340	572	778	1679	450	694	644	889	892	1832	630	1286	1166
16	406	610	1745	560	534	504	610	838	1993	450	984	834	991	994	2106	710	1841	1511
18	432	660	2010	560	669	619	914	930	2181	560	1306	1051	1092	1095	2489	710	2585	2150
20	457	711	2330	650	810	770	991	1010	2376	560	1546	1226	1194	1200	2662	760	3108	2558
24	508	813	2784	650	1430	1143	1165	2860	710	2360	1910	1397	1406	2970	760	4688	3898	
28	610	914	3236	660	2067	2157	1346	1372	3302	760	3660	3010	1594	1562	3562	760	6050	4980
30	610	914	3417	660	2189	2259	1397	1422	3772	760	4350	3460	1651	1663	3880	760	6946	5710
36	711	1016	4109	710	3563	3633	1727	1756	4312	760	6850	4990	2083	2098	4560	760	9740	8140
40	762	1067	4670	800	4703	4733	1930	-	4791	760	8460	6160	2387	-	5273	800	10550	8540
42	813	1092	5430	800	4600	4625	1981	-	5032	900	9500	6800	2489	-	6098	900	10950	8770
48	864	1168	5525	900	7110	7050	2215	-	5522	900	12400	9000	-	-	-	-	-	-
52	914	1372	5766	900	8500	8550	-	-	-	-	-	-	-	-	-	-	-	-

Gate Valve Dimensions & Weights (900#, 1500#, 2500#)

NPS (in)	Class 900						Class 1500						Class 2500					
	A <sub>1</sub> & A <sub>3</sub>	A <sub>2</sub>	H	W	Wt. (kg)		A <sub>1</sub> & A <sub>3</sub>	A <sub>2</sub>	H	W	Wt. (kg)		A <sub>1</sub> & A <sub>3</sub>	A <sub>2</sub>	H	W	Wt. (kg)	
					RF	BW					RF	BW					RF	BW
2	368	371	539	300	82	59	368	371	539	300	82	59	451	454	619	300	93	58
2.5	419	422	670	300	155	70	419	422	670	300	155	130	508	514	809	450	150	100
3	381	384	672	355	165	130	457	460	738	400	182	147	578	584	809	450	201	131
4	457	460	782	400	174	134	470	473	782	400	174	134	673	683	1073	630	606	491
6	610	621	1076	560	453	358	705	711	1196	450	617	442	914	927	1451	610	1590	1300
8	737	740	1411	450	780	625	832	841	1546	560	1400	1200	1022	1038	1600	610	2440	2000
10	838	841	1720	560	1248	1028	991	1000	1688	710	2001	1606	1270	1292	2096	610	4574	3800
12	965	968	1965	560	1542	1290	1130	1146	2090	710	3816	3211	1422	1445	2292	760	7180	6000
14	1029	1038	1902	610	2220	1890	1257	1276	2162	760	4115	3200	-	-	-	-	-	-
16	1130	1140	2051	610	3000	2565	1384	1406	2486	760	6950	6000	-	-	-	-	-	-
18	1219	1232	2256	760	3870	3300	1536	1559	2762	760	9000	7740	-	-	-	-	-	-
20	1321	1333	2800	760	4860	4050	1664	1686	3102	910	11130	9560	-	-	-	-	-	-
24	1549	1568	3150	760	7300	6120	1943	1972	3721	910	16270	13770	-	-	-	-	-	-