

PRODUCT DETAILS:-

GICOB™ GCP Model: Piston Check Valves Design

Features

- Non-slam check prevents pressure surges during closing
- Top entry for easy maintenance
- Clamped seat ring makes replacing parts hassle free
- Size range 1/2" to 24"
- Pressure ratings up to 2500lb

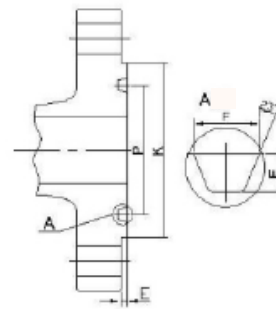
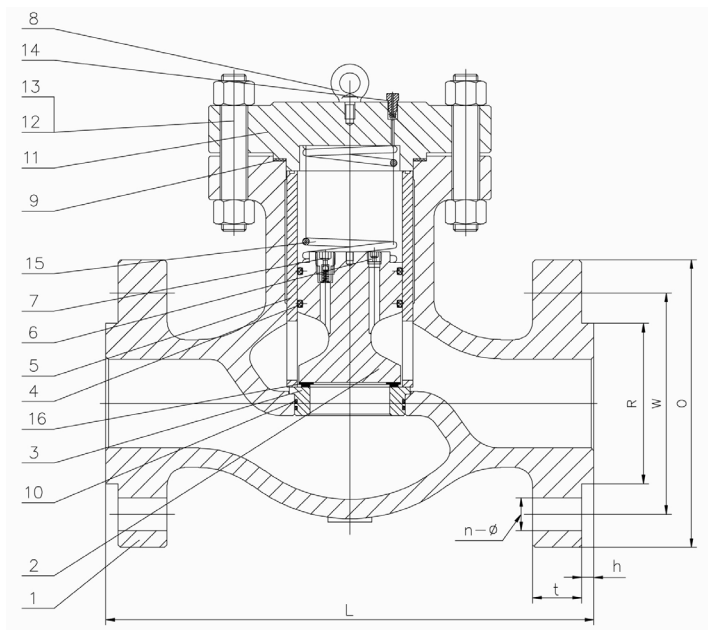

Ring Type Joint Connection

GICOB™ GCP Model: Piston Check Valve Part List

Item	Description	Valve Material			
		Carbon Steel	Alloy Steel	Stainless Steel	
1	Body	A216 WCB	A217 LCB	A351 CF8	A351 CF8M
2	Piston			A182 F316	
3	Seat			A182 F316	
4	Piston Ring			Viton	
5	Liner			A182 F316	
6	Orifice Plug			Stainless Steel	
7	Ball Check			Stainless Steel	
8	Lifting Lug			AISI 1020	
9	Gasket			Flexible Graphite + SS	
10	Seat Ring	Viton	Teflon	Viton	
11	Bonnet	A105	A105	A351 CF8	A351 CF8M
12	Bolt		A193 B7		A193 B8
13	Nut		A194 2H		A194 8
14	Vent			Stainless Steel	
15	Spring			Inconel X750	
16	Seal Surface			Stainless Steel	

Piston Check Valve Dimensions (150#, 300#, 600#)

NPS (in)	Class 150				Class 300				Class 600			
	O	W	R	L	O	W	R	L	O	W	R	L
1/2"	89	60.5	35	108	95	66.5	35	216	95	66.5	35	165
3/4"	98	70	43	117	117	82.5	43	229	118	82.5	43	190
1"	108	79.5	51	127	124	89	51	241	124	89	51	216
1-1/4"	117	89	64	140	133	98.5	64	267	133	98.5	64	229
1-1/2"	127	98.5	73	165	156	114.5	73	292	156	114.5	73	241
2"	152	120.5	92	203	165	127	92	318	165	127	92	292
2-1/2"	178	139.5	105	216	190	149	105	356	173	149	100	330
3"	190	152.5	127	241	210	168.5	127	400	190	168	127	356
4"	229	190.5	157	292	254	200	157	444	210	216	157	432
5"	254	216	186	356	279	235	186	533	330	266.5	186	508
6"	279	241.5	216	406	318	270	216	574	356	292	216	559
8"	343	298.5	270	495	381	330	270	622	419	349	270	660
10"	406	362	324	622	445	387.5	324	670	508	432	324	787
12"	483	432	381	698	521	451	381	711	559	489	381	838
14"	533	476	413	787	584	514.5	413	838	603	527	413	889
16"	597	540	470	914	648	571.5	470	864	686	603	470	991
18"	635	578	533	978	711	628.5	533	978	743	654	533	1092
20"	699	635	584	978	775	686	584	1016	813	724	584	1194
24"	813	749.5	692	1275	914	813	692	1346	940	838	692	1397

Piston Check Valve Dimensions (900#, 1500#, 2500#)

NPS (in)	Class 900				Class 1500				Class
	O	W	R	L	O	W	R	L	2500
1"	149	101.6	51	254	149	101.6	51	254	Upon request
1-1/4"	159	111.1	64	279	159	111.1	64	279	
1-1/2"	178	123.8	73	305	178	123.8	73	305	
2"	216	165.1	92	371	216	165.1	92	368	
2-1/2"	244	190.5	105	384	244	190.5	105	419	
3"	244	190.5	127	422	267	203.2	127	470	
4"	292	235	157	460	311	241.3	157	546	
5"	349	279.4	186	562	375	292.1	186	673	
6"	381	317.5	216	613	394	317.5	216	705	
8"	470	393.7	270	740	485	393.7	270	832	
10"	545	469.9	324	741	585	482.6	324	991	
12"	610	533.4	381	968	675	517.5	381	1130	
14"	640	558.8	413	1038	750	635	413	1257	
16"	705	615.9	470	1140	825	704.8	470	1384	
18"	785	685.8	533	1232	915	774.7	533	1537	
20"	855	749.3	584	1334	985	831.8	584	1664	
24"	1040	901.7	692	1568	1170	990.6	692	1943	